

MAGNUM LIGHT TOWERS

Magnum Light Towers are built and designed for the most extreme environments, from deserts to the frozen tundra. The Light Tower offers complete flexibility with 360° rotation. In addition the 4 – 1,000 watt metal halide lights will fully illuminate up to seven acres. Our unparalleled customer service/technical support teams and heavy-duty equipment is what gives our customers the ultimate “return on investment.”

Tough

- Full tubular steel frame trailer
- 30 foot all-steel mast
- 4 – 1,000 watt metal halide lights
- 4 point outrigger stance withstands 65+ MPH winds

Reliable

- 4-stroke diesel engine
- Marathon generator
- Low oil/high temperature automatic shutdowns
- Protective start limit breaker
- Individual light breaker switches
- Individual ballast boxes
- 2 year – 2,000 hour warranty

Easy to Use

- 360° mast rotation
- 120 V and 240 V convenience outlets
- Hour meter engine
- Lockable cabinet
- DOT running light package
- Fork guides on the mast and under the trailer
- Easy access for service

ADVANCED FEATURES:

- FULL TUBULAR STEEL FRAME TRAILER
- 4-STROKE DIESEL ENGINE
- MARATHON GENERATOR
- 120 V AND 240 V CONVENIENCE OUTLETS

For more information:

Call: 1-800-926-9768 Fax: 920-361-2214 Or visit: www.M-P-LLC.com

EMPOWERING REAL PEOPLE

215 POWER DRIVE BERLIN, WISCONSIN 54923-2420
™ TRADEMARK AND ® REGISTERED TRADEMARK OF MAGNUM PRODUCTS LLC



4000 SERIES

ALSO AVAILABLE IN 3000 AND 5000 SERIES

SPECIFICATIONS

| | |
|----------------|--|
| Engine: | Mitsubishi 4-stroke, diesel, liquid-cooled (Standard 6, 8 & 15kw) Isuzu 4 cylinder, diesel (Standard 20kw) |
| Generator: | 4-pole, brushless, self-regulated |
| Mast & Cord: | 30' maximum extension, coiled |
| Lights: | 4 – 1,000 watt metal halide |
| Ballast Type: | Coil & core |
| Lumens: | 440,000 |
| Coverage: | 5 – 7 acres |
| Other Options: | 6, 8, 15 or 20KW generator sets in 50 or 60 HZ 4 or 6 metal halide or high pressure sodium lights Dual manual or electric mast winch system Liquid containment system Super quiet enclosure 56 gallon fuel capacity CAT (6 & 8KW) or Kubota (6KW) power available Spare tire/holder Various cold weather features Timer/controller Lower radiator hose engine heater Auto light controller Magnum is flexible enough to meet your custom product needs |

Magnum provides a light tower model for every need from the narrow bodied MLT 3060, to the super stable MLT 5200 with inside light storage capability.

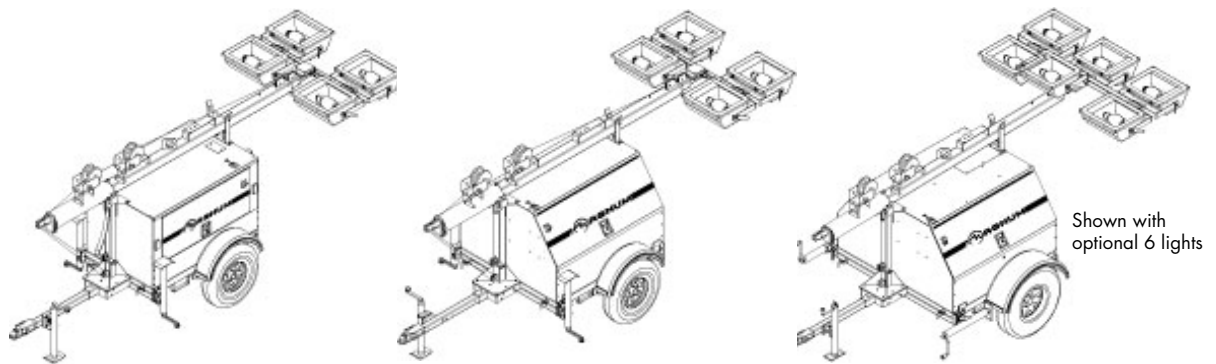

| | 3000 Series | 4000 Series | 5000 Series |
|-------------------------------|-------------|-------------|-------------|
| Generator (kw) | 6/8/15/20 | 6/8/15/20 | 6/8/15/20 |
| Fuel Tank (gal) | 30/30/30/56 | 30/30/30/56 | 30/30/30/56 |
| Trailer Width (in) | 49 | 62 | 79 |
| Outrigger Width (in) | 98 | 140 | 151 |
| Unit Height (in) | 68 | 68 | 70 |
| Unit Length w/ Lights (in) | 170 | 170 | 170 |
| Unit Length w/o Lights (in) | 150 | 150 | 150 |
| Trailer Length (in) | 115 | 115 | 115 |
| Unit Weight (lbs) ranges from | 1630 – 1650 | 1840 – 2520 | 1920 – 2600 |

For more information:

Call: 1-800-926-9768 Fax: 920-361-2214 Or visit: www.M-P-LLC.com

SPECIFICATIONS SUBJECT TO CHANGE
CONTACT YOUR REPRESENTATIVE FOR DETAILS

